

The details shown on this drawing are confidential and the drawing is the exclusive property of Halliday Clark Limited. No use, copy or disclosure of the drawing may be made without our permission and it is to be returned to Halliday Clark Limited when required. Halliday Clark Limited take no responsibility for the use of this drawing for any purpose other than that which it was intended. All dimensions are in millimeters unless stated otherwise. All dimensions should be verified on site prior to commencement of works. Do not scale from this drawing. All works must be in accordance with British Standards, EC Standards, Health & Safety at work act & all other relevant regulations & Bye Laws. Any discrepancies should be brought to the attention of Halliday Clark Limited.

NOTES

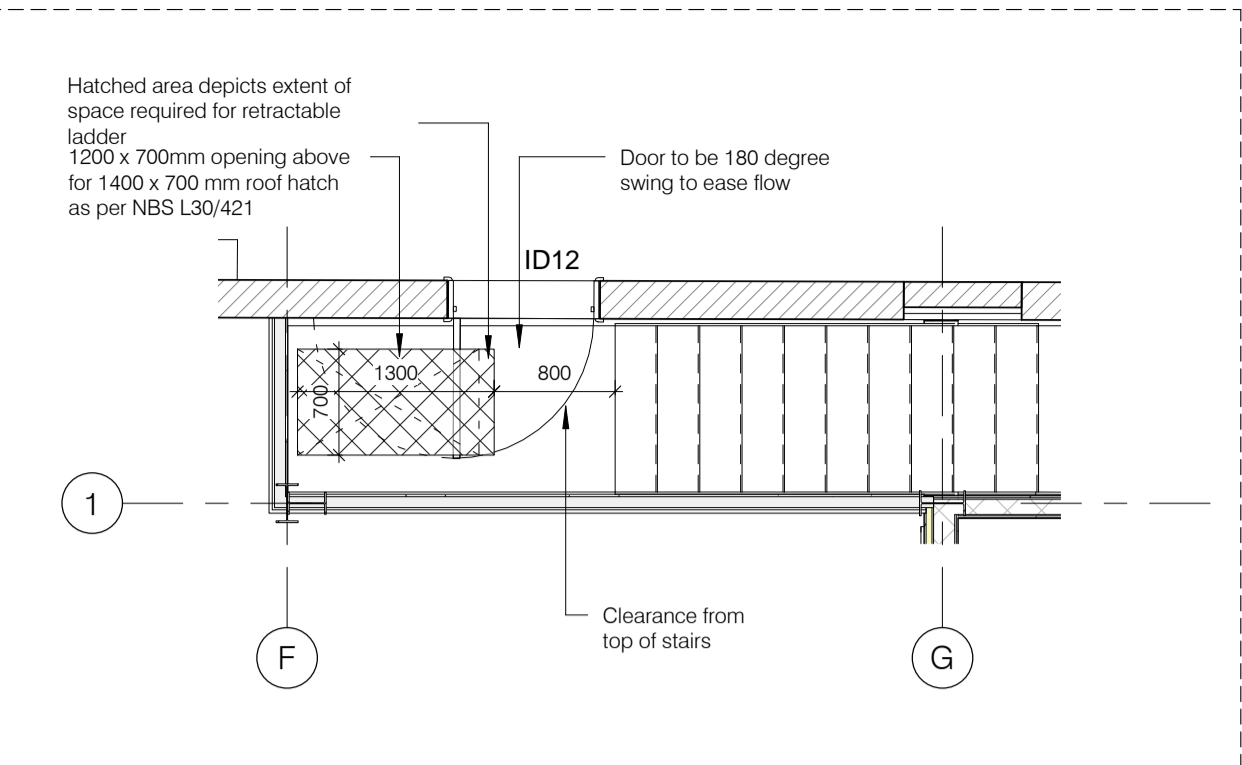

2 Emergency Exit Stairwell
1 : 50

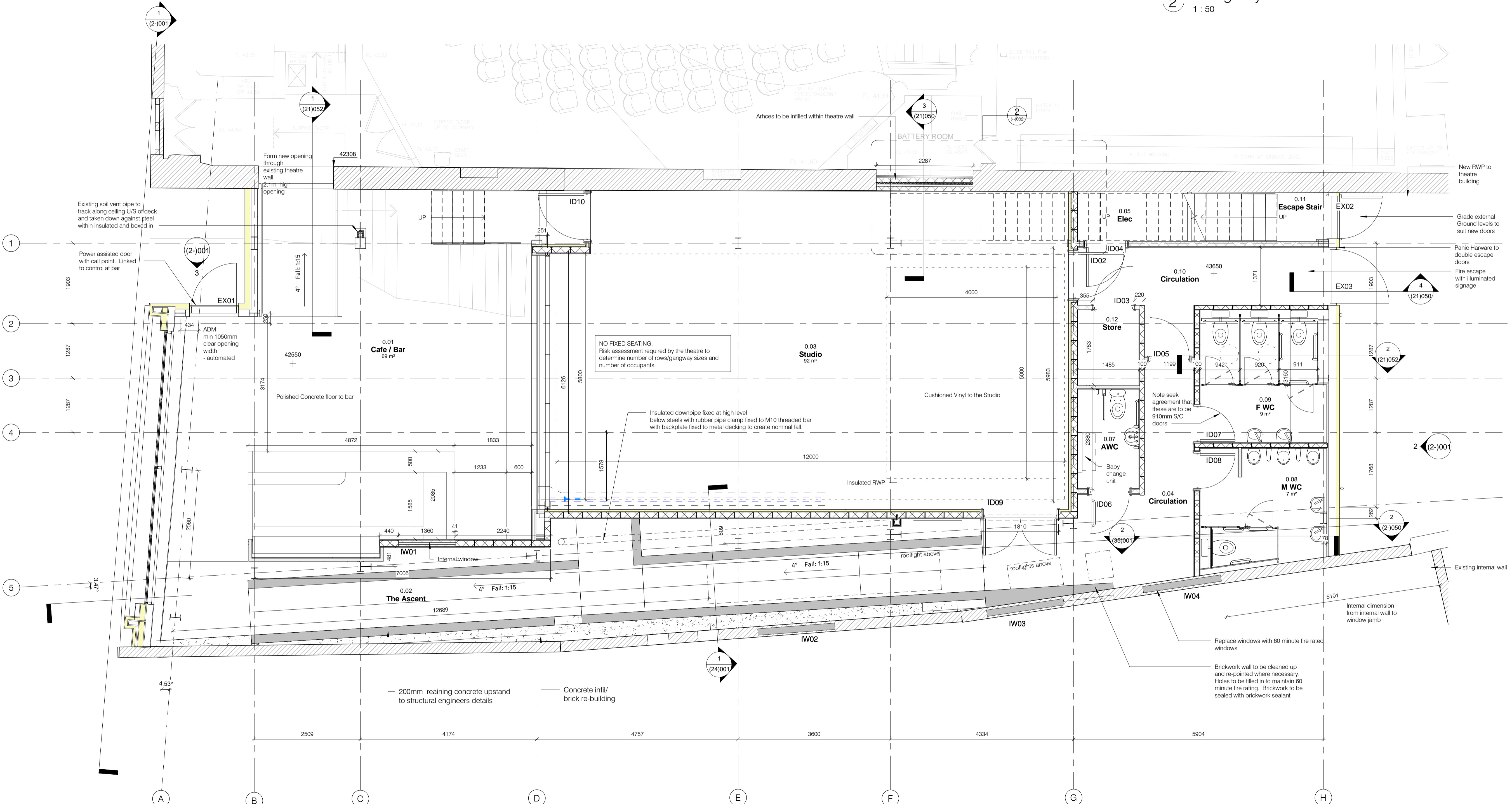

1 Level 0 GA
1 : 50

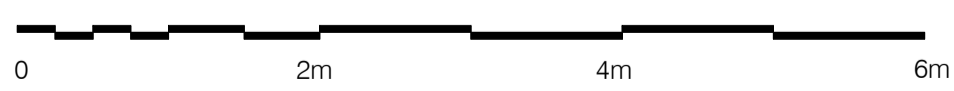

H	25.04.2018	Final Construction issued.	EB	Checker
G	22.09.2017	Sliding folding partition and glass balustrade introduced back onto drawing.	DRWN	CHKD
F	12.07.2017	Revisions to Ramp & Restaurant wall strengthening.		
E	23.05.2017	Revisions following VE items omitted. Issued for construction.		
D	23.03.2017	Tender addendum issue.		
C	21.02.2017	Toilet walls amended to blockwork for EB support of plant. Section references added.		
B	07.02.2017	Further Revision to Male WC.	EB	
A	06.02.2017	Omission of Cleaners sink and revision of stairs and toilet layout.	EB	

INITIAL ISSUE	01/24/17	EB	Checker
REVISION - DATE		DRWN	CHKD

FINAL CONSTRUCTION

The Centre for Creativity Westgate
Wakefield
WF1 2TE

FOR
Wakefield Theatre Trust

GA Level 0 (B&W)

Scale 1 : 50

HALLIDAY CLARK
ARCHITECTS

Halliday Clark Limited T 01943 604 123
21 The Grove E info@hallidayclark.co.uk
Ilkley LS29 9LW W hallidayclark.co.uk